



**Weather Station with Remote  
Color Changing Light Box  
Model: BAR989HG / BAR989HGA**

**USER MANUAL**



© 2005 Oregon Scientific. All rights reserved.

086L004157-014





2

# Weather Station with Remote Color Changing Light Box

## Model: BAR989HG / BAR989HGA

### USER MANUAL

#### CONTENTS

<b>Introduction</b> .....	<b>3</b>
<b>Product Overview</b> .....	<b>4</b>
Front View .....	4
Back View .....	5
LCD Display .....	6
Light Box - LR101 .....	9
Remote Sensor (RTGR328N/RTGR328NA) .....	10
<b>Getting Started</b> .....	<b>11</b>
Batteries .....	11
AC Adapter (Main Unit) .....	12
AC Adapter (LR101) .....	12
Change Settings .....	12
<b>Remote Sensor</b> .....	<b>13</b>
Set Up Thermo / Hygro Sensor .....	13
Sensor Data Transmission .....	14
Search for Sensor .....	15
<b>Clock and Calendar</b> .....	<b>15</b>
Clock Reception .....	15

Turn Clock Reception ON / OFF .....	16
Set Clock .....	16
Switch Clock Display .....	17
<b>Alarms</b> .....	<b>17</b>
Set Daily Alarm .....	17
Set Pre-Alarm .....	17
Activate Alarm .....	18
Snooze .....	18
<b>Barometer</b> .....	<b>18</b>
View Barometer Area .....	18
Select Measurement Unit .....	18
View Barometer History .....	18
Bar Chart Display .....	19
Set Altitude .....	19
<b>Weather Forecast</b> .....	<b>19</b>
Weather Forecast Icons .....	19
<b>UV Measurement - Optional Sensor</b> .....	<b>20</b>
New Additional UV Features .....	20
<b>Temperature and Humidity</b> .....	<b>21</b>
View Temperature and Humidity Area .....	21
Select Measurement Unit .....	22
Select Sensor Channel .....	22
Minimum / Maximum Records .....	22
Temperature and Humidity Trend .....	22



Comfort Zone .....	22
Heat Index .....	23
<b>Backlight .....</b>	<b>23</b>
<b>Reset System .....</b>	<b>23</b>
<b>Light Box .....</b>	<b>23</b>
<b>Safety and Care .....</b>	<b>24</b>
<b>Warnings .....</b>	<b>24</b>
<b>Troubleshooting .....</b>	<b>25</b>
<b>Specifications .....</b>	<b>25</b>
<b>About Oregon Scientific .....</b>	<b>27</b>
<b>EC-Declaration of Conformity .....</b>	<b>27</b>
<b>FCC Statement .....</b>	<b>28</b>
Declaration of Conformity .....	28



## INTRODUCTION

Thank you for selecting the Oregon Scientific™ BAR989HG / BAR989HGA Weather Station with Remote Color Changing Light Box. This powerful device bundles time keeping, weather monitoring, indoor and outdoor temperature and humidity readings, barometric trends and altitude adjustment, into a single tool you can use from the convenience of your home.

In this box, you will find:

- Main unit
- Remote sensor (RTGR328N or RTGR328NA)
- 1 remote color light box
- 2 x 6V AC adapter
- Batteries

Additional sensors compatible with the main unit:

- UV sensor (UVR128 / UVR138)
- Thermo-Hygro Sensors;  
BAR989HG only - THGR328N 5-Channel  
/ THGR228N 3-Channel  
/ THWR288 3-Channel

BAR989HGA only - THGR328NA 5-channel  
/ THGR238NA 3-channel  
/ THWR288A 3-channel

Additional sensors are sold separately. Please contact your local retailer for more information.

Keep this manual handy as you use your new product. It contains practical step-by-step instructions, as well as technical specifications and warnings you should know.

## PRODUCT OVERVIEW

### FRONT VIEW

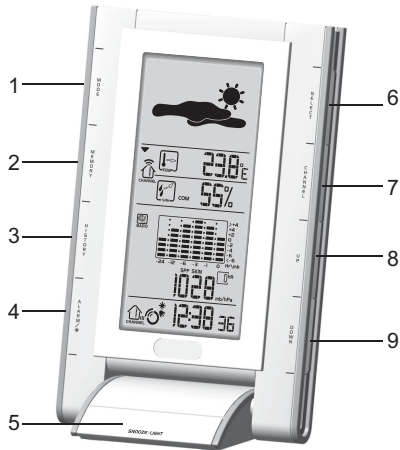

1. **MODE:** Change settings / display
2. **MEMORY:** View current, maximum and minimum temperature / humidity / UV readings
3. **HISTORY:** View historical barometer and UV readings
4. **ALARM / \*:** View alarm status; set alarm
5. **SNOOZE / LIGHT:** Activate 8-minute snooze or backlight
6. **SELECT:** Switch Areas
7. **CHANNEL:** Switch remote sensor display
8. **UP:** Increase setting / activate clock radio-signal reception
9. **DOWN:** Decrease setting / deactivate clock radio-signal reception



## BACK VIEW

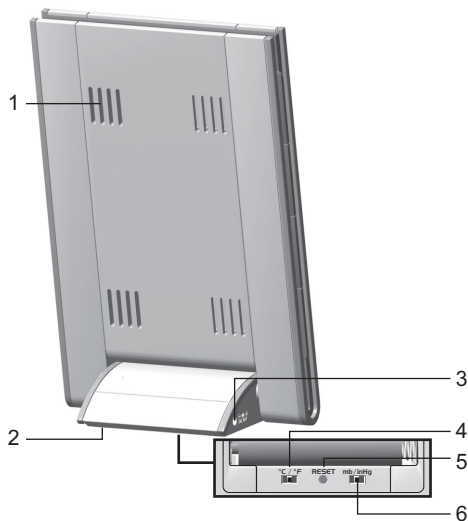

1. Ventilation holes
2. Battery compartment (bottom)
3. AC adapter socket
4. °C / °F switch (in battery compartment)
5. **RESET** button (in battery compartment)
6. **mb / inHg** switch (in battery compartment)

You can adjust the angle of the clock display as shown below:

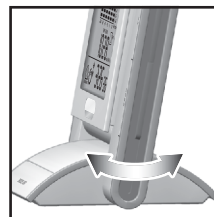

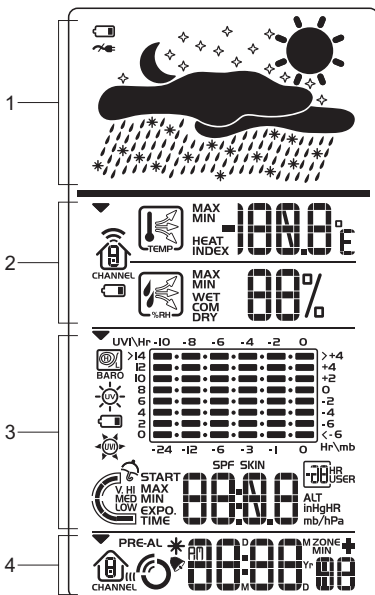

- 1. Weather Forecast Area:** Animated weather forecast
- 2. Temperature / Humidity / Comfort Zone Area:** Readings and trend lines; comfort zone; sensor channel number
- 3. UVI / Barometer Area:** UV level and barometric pressure bar chart; UV Index and barometric readings
- 4. Clock / Alarm / Calendar Area:** Clock; alarms; calendar





### Weather Forecast Area

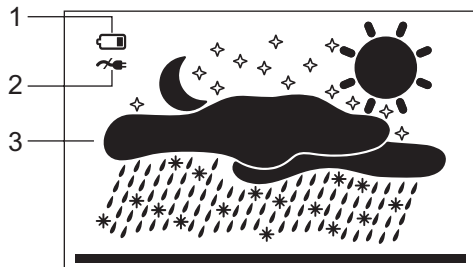

1. Low battery icon for main unit
2. AC adapter icon - displays when unplugged
3. Weather display

### Temperature / Humidity / Comfort Zone Area

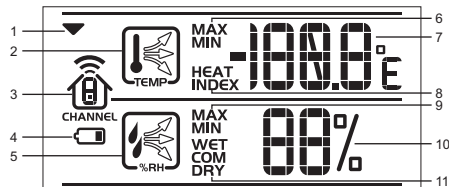

1. Selected Area icon
2. Temperature trend
3. Channel number (1-5) / reception status
4. Low battery icon for remote sensor
5. Humidity trend
6. MAX / MIN temperature
7. Temperature - °C / °F
8. Heat Index
9. MAX / MIN humidity
10. Humidity
11. Comfort levels

## UVI / Barometer Area

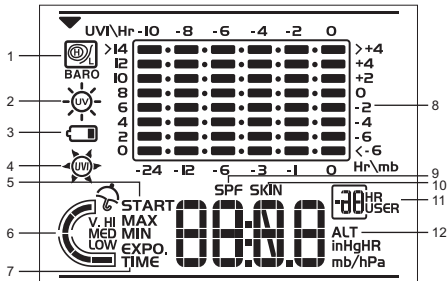

1. Barometric pressure is showing
2. UV is showing
3. Low battery icon for UV sensor
4. UVI value is showing
5. UV exposure time countdown has started
6. UV index level
7. UV exposure time for user
8. Barometer / UV chart
9. SPF applied to user for UV exposure
10. User skin type for UV exposure
11. User no. (for UV Mode) or hour history for UV / Barometric pressure reading
12. Altitude / barometric pressure / UVI reading

8

## Clock / Alarm / Calendar Area



1. Pre-Alarm is set
2. Pre-Alarm display / Pre-Alarm setting
3. Channel with clock reception is locked
4. Clock reception icon
5. Daily Alarm is set
6. Offset time-zone
7. Time / date / calendar



## LIGHT BOX - LR101

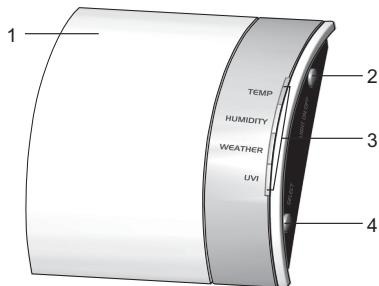

1. Light box display area
2. **LIGHT ON / OFF:** Turns light box ON or OFF
3. Red LED: Lights up next to the weather information you are viewing
4. **SELECT:** Selects temperature, humidity, weather forecast or UV weather information

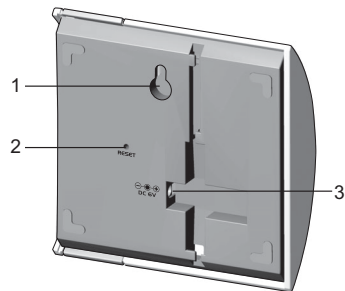

1. Wall mount hole
2. **RESET:** Resets the unit
3. AC adapter hole

## REMOTE SENSOR (RTGR328N / RTGR328NA)

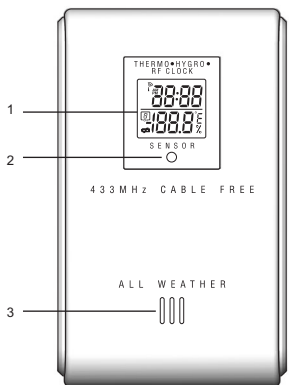

1. LCD display
2. LED status indicator
3. Ventilation duct

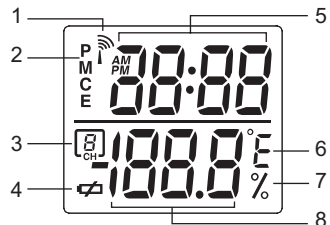

1. Signal reception
2. US time zone (RTGR328NA only)
3. Channel number
4. Low battery icon
5. Time
6. Temp (°C or °F)
7. Humidity %
8. Temp / Humidity



## GETTING STARTED

### BATTERIES

Batteries are supplied with this product:

- Main unit 4 x UM-4 (AAA) 1.5V
- Remote unit 2 x UM-3 (AA) 1.5V

Insert batteries before first use, matching the polarity as shown in the battery compartment. For best results, install batteries in the remote sensor before the main unit. Press **RESET** after each battery change.

To install the main unit batteries:

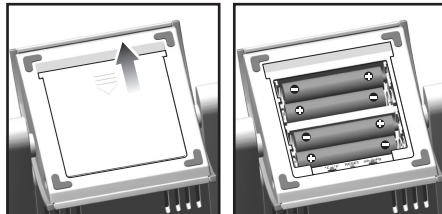

**NOTE** Do not use rechargeable batteries.

 shows when batteries are low.

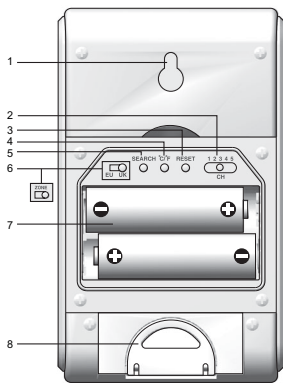

1. Wall mount
2. **CHANNEL** switch (1-5)
3. **RESET**
4. **°C / °F**
5. **SEARCH**
6. **EU / UK** radio signal format switch (RTGR328N only); **ZONE** (RTGR328NA only)
7. Battery compartment
8. Fold-out stand

**NOTE** It is recommended that you use alkaline batteries with this product for longer performance.

UNIT	LOCATION
Main	Weather Forecast Area
Remote	Temperature / Humidity Area
UV Sensor	UVI / Barometric Pressure Area

**NOTE** The UV sensor is an optional item.

#### AC ADAPTER (MAIN UNIT)

The batteries serve as a back-up power supply. For continuous use, please install the AC adapter at the base of the unit:

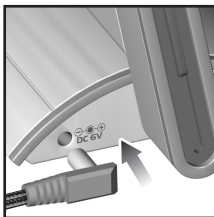

 shows in the Weather Forecast Area when the AC adapter is not plugged in.



#### AC ADAPTER - LR101

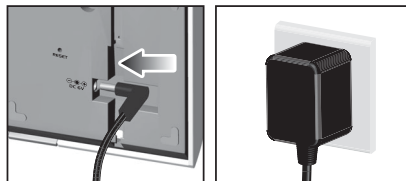

#### CHANGE SETTINGS

1. Press **SELECT** to switch between Areas. ▼ indicates the selected Area.

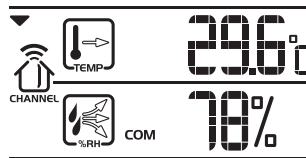

2. Most Areas have alternate display options (for example, Clock / Alarm or Barometer / UVI). Press **MODE** to switch options, or **ALARM** / \* to switch between clock and alarm.
3. Press and hold **MODE** for 2 seconds to enter setting mode.
4. Press **UP** or **DOWN** to change settings.
5. Press **MODE** to confirm.





## REMOTE SENSOR

This product is shipped with the RTGR328N/RTGR328NA Thermo Hygro Sensor. The main unit can collect data from up to 6 sensors (5 Thermo / Hygro Sensors and 1 UV Sensor). Additional sensors are compatible as follows:

- BAR989HG only - THGR328N / THGR328NA 5-Channel / THGR228N 3-Channel / THWR288 3-Channel
- BAR989HGA only - THGR238NA 5-channel / THGR238NA 3-channel / THWR288A 3-Channel

(Additional sensors are sold separately. Contact your local retailer for more information.)

The sensor collects and transmits temperature and humidity readings, along with time and date information. This product is designed to automatically synchronize the time and date once it is brought within range of a radio signal:

- DCF-77 generated from Frankfurt, Germany for Central Europe
- MSF-60 generated from Rugby, England
- WWVB-60 generated from the atomic clock in Fort Collins, Colorado.

The sensor collects the radio signals whenever it is within 1500 km (932 miles) of a signal.

## SET UP THERMO / HYGRO SENSOR

1. Open the battery compartment with a small Phillips screwdriver.
2. Insert the batteries.
3. \* RTGR328N only - Set the channel and radio signal format. The switches are located in the battery compartment. If you are using more than one sensor, select a different channel for each sensor. Slide the **EU / UK** switch to the appropriate setting.  
\* RTGR328NA only - Set the channel. The switch is located in the battery compartment. If you are using more than one sensor, select a different channel for each sensor.
4. Press **RESET**. Then set the temperature unit to your preferred setting °C / °F.
5. \* RTGR328NA only - Press **ZONE** to select the US time zone (P for Pacific, M for Mountain, C for Central or E for Eastern).
6. Close the battery compartment.

To fold out the stand:

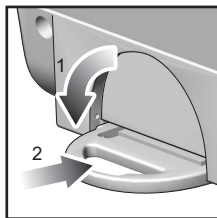

For best results:

- Place the sensor out of direct sunlight and moisture.
- Do not place the sensor more than 70 metres (230 feet) from the main (indoor) unit.
- Position the sensor so that it faces the main (indoor) unit, minimizing obstructions such as doors, walls, and furniture.
- Place the sensor in a location with a clear view to the sky, away from metallic or electronic objects.
- Position the sensor close to the main unit during cold winter months as below-freezing temperatures may affect battery performance and signal transmission.

**NOTE** The transmission range may vary and is subject to the receiving range of the main unit.

You may need to experiment with various locations to get the best results.

Standard Alkaline batteries contain significant amounts of water. Because of this they will freeze in low temperatures of approximately  $-12^{\circ}\text{C}$  ( $10^{\circ}\text{F}$ ). Disposable Lithium batteries have a much lower threshold for temperature with an estimated freezing range of below  $-40^{\circ}\text{C}$  ( $-40^{\circ}\text{F}$ ).

Wireless ranges can be impacted by a variety of factors such as extremely cold temperatures. Extreme cold may temporarily reduce the effective range between the sensor and the base station. If the unit's performance fails due to low temperature, the unit will resume proper functioning as the temperature rises to within the normal temperature range (i.e. no permanent damage will occur to the unit due to low temperatures). The Liquid Crystal Display in outdoor thermometers will remain operational to  $-7^{\circ}\text{C}$  ( $-20^{\circ}\text{F}$ ) with adequate power.

#### SENSOR DATA TRANSMISSION

Data is sent from the sensor(s) every 60 Seconds. The reception icon shown in the Temperature / Humidity Area indicates the status.

ICON	DESCRIPTION
	Main unit is searching for sensors.
	At least 1 channel has been found.





	Sensor 1 is sending data. (The number shows which sensor is selected.)
--- shows in Temp / Humidity Area	The selected sensor cannot be found. Search for the sensor or check batteries.

### SEARCH FOR SENSOR

To search for a Thermo / Hygro sensor, press **SELECT** to navigate to the Temperature / Humidity Area. ▼ will show next to the Area. Then, simultaneously press and hold **MEMORY** and **CHANNEL** for 2 seconds.

To search for the UV sensor, press **SELECT** to navigate to the UVI / Barometer Area. ▼ will show next to the Area. Then, press and hold **MEMORY** and **CHANNEL** for 2 seconds (the UV sensor is an optional item).

**NOTE** If the sensor is still not found, check the batteries.

### CLOCK AND CALENDAR

This product tracks the time and date based on radio signals from the remote sensor, or manual settings that you enter.



### CLOCK RECEPTION



The time and date are automatically updated by radio signals from official time-keeping organizations unless you disable this feature. See the Remote Sensor section for more information.

Initial reception takes 2-10 minutes, and is initiated when you first set up the unit, and whenever you press **RESET**. If the radio signal is weak, it can take up to 24 hours to get a valid signal reception. Once complete, the reception icon will stop blinking.

The  icon shown in the Clock Area indicates 2 factors:



- Connection between the main unit and the sensor that collects radio signals ( III )
- Radio signal reception ( ☺ )

How these signals work together:

ICON	MEANING
	The unit has contact with the sensor and has synchronized the time.
	The unit has contact with the sensor but the time has not been synchronized.





ICON	MEANING
	The unit has lost contact with the remote sensor but the time is synchronized.
	The unit has lost contact with the remote sensor and the time is not synchronized.
	The unit cannot reach the remote sensor.

**NOTE** To force a manual search for the clock signal reception, press and hold **SEARCH** on the sensor for 2 seconds.

#### TURN CLOCK RECEPTION ON / OFF

If you wish to manually set the clock, you must first disable the clock radio signal reception feature. To do this, navigate to the Clock / Alarm Area. Then, press and hold **DOWN** on the main unit for 2 seconds. To enable it, navigate to the Clock / Alarm Area, then press and hold **UP** for 2 seconds.

Clock radio reception enabled:



Clock radio reception disabled:



#### SET CLOCK

You only need to do this if you have disabled clock radio signal reception, or if you are too far from the radio signal.

1. Press **SELECT** to navigate to the Clock Area. will show next to the Area.
2. Press and hold **MODE** for 2 seconds.
3. Select the time zone offset hour (+ / -23 hours), 12 / 24 hour format, hour, minute, year, date / month format, month, date and display language.
4. Press **UP** or **DOWN** to change the setting.
5. Press **MODE** to confirm.

**NOTE** The language options are (E) English, (F) French, (D) German, (I) Italian, and (S) Spanish. The language you select determines the weekday display.

**NOTE** BAR989HGA only - If no time zone hour offset is set, the time shown will be Pacific Time. To change to another US time zone, select an hour offset accordingly. The time zone options and their related hour offset times are Pacific (UTC-8), Mountain (UTC-7), Central (UTC-6) and Eastern (UTC-5).





### SWITCH CLOCK DISPLAY

Press **SELECT** to navigate to the Clock Area. ▼ will show next to the Area.

Press **MODE** to toggle between:

- Clock with seconds
- Clock with day
- Clock with time-zone offset
- Calendar

### ALARMS

This product has 2 alarms: The Daily Alarm and a Pre-Alarm for snowy weather. The Daily Alarm can be set to go off at the same time every day. The Pre-Alarm sounds only when the Daily Alarm is activated and the recorded temperature from Channel 1 Sensor falls to 2°C (35.6°F) or below.

#### SET DAILY ALARM

1. Press **SELECT** to navigate to the Clock Area. ▼ will show next to the Area.
2. Press **ALARM / \*** to view the alarm. (AL will show at the top.)
3. Press and hold **ALARM / \*** for 2 seconds.
4. Select the hour and minute. Press **UP** or **DOWN** to change settings.
5. Press **ALARM / \*** to confirm.
6. The Daily Alarm icon 🗓 will appear when the alarm is set.

#### SET PRE-ALARM

The Pre-Alarm can be set to sound 15, 30, 45, or 60 minutes before the Daily Alarm. It will sound whenever the recorded temperature from Channel 1 Sensor falls to 2°C (35.6°F) or below.

For example, if you set the alarm to 7:00 AM, and the Pre-Alarm to 45 minutes, the Pre-Alarm will sound at 6:15 AM provided the outdoor temperature at Channel 1 Sensor is 2°C or below.

1. Set up and activate the Daily Alarm.
2. Press **ALARM / \*** to switch to Pre-Alarm view. (PRE-AL will show at the top.)
3. Press and hold **ALARM / \*** for 2 seconds.
4. Press **UP** or **DOWN** to select 15, 30, 45 or 60 minutes. This is the amount of time the Pre-Alarm will sound BEFORE the Daily Alarm. The Pre-Alarm is automatically activated when you select a time.
5. Press **ALARM / \*** to confirm.

\* shows when the Pre-Alarm is set.

**NOTE** The Daily Alarm will NOT function until the next day if the Pre-Alarm has been triggered. Also, if you deactivate the Daily Alarm, the Pre-Alarm is automatically deactivated.





## ACTIVATE ALARM

Navigate to the Clock Area, then press **ALARM** / \* to switch to Daily Alarm or Pre-Alarm view. To activate or deactivate the alarm, press **UP** or **DOWN**.

When the alarm time is reached, the backlight will be on for 8 seconds and crescendo alarm will sound for 2 minutes. Press any key (except snooze) to silence the alarm. It will sound at the same time the next day.

## SNOOZE

Press **SNOOZE** / LIGHT to temporarily disable the alarm for 8 minutes. ☹ or \* will blink while snooze is on.

## BAROMETER

This product tracks fluctuations in barometric pressure to provide the weather forecast, and the current and past 24 hours barometric pressure history measurements are recorded by the main (indoor) unit.

## VIEW BAROMETER AREA

Press **SELECT** to navigate to the Barometer Area.

If  is **NOT** shown, press **MODE**.

Barometric data is shown in 2 areas at the bottom of the display. The upper area shows a 24-hour bar chart. The lower area shows current and historical readings.

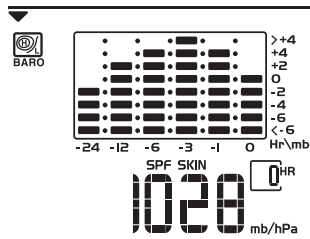

## SELECT MEASUREMENT UNIT

Slide the **mb / inHg** switch (in the clock battery compartment), to change the display unit.

## VIEW BAROMETER HISTORY

Navigate to the Barometer Area. Then press **HISTORY** repeatedly to scroll through the measurements. The number shown in the HR box indicates how long ago each measurement was taken (e.g. 2 hours ago, 3 hours ago, etc.).



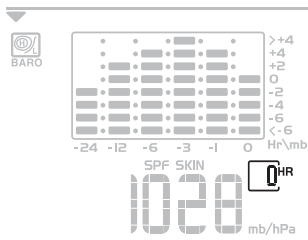

### BAR CHART DISPLAY

The bar chart visually shows atmospheric changes from the current hour (0) to 24 hours prior (-24).

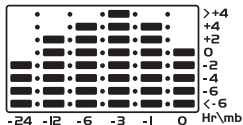

### SET ALTITUDE

Set the altitude to match how far above or below sea level you are living. This ensures that the barometric pressure readings are accurate.

1. Navigate to the Barometer Area.
2. Press and hold **HISTORY** for 2 seconds.
3. Press **UP** or **DOWN** to set the altitude in 10-metre

- increments (-100m to 2500m / -328 to 8202 feet).
4. Press **HISTORY** to confirm.



### WEATHER FORECAST

This product forecasts the next 12 to 24 hours of weather within a 30-50 km (19-31 mile) radius. The forecast is based on barometric pressure trend readings.

### WEATHER FORECAST ICONS

ICON	DESCRIPTION
<p>Day / Night</p>	Clear
<p>Day / Night</p>	Partly cloudy
	Cloudy



ICON	DESCRIPTION
	Rainy
	Snowy

**NOTE** The night time icon displays from 6 PM to 6 AM. When the Channel 1 sensor records a temperature of 2°C (35.6°F) or lower, the **RAINY** icon becomes **SNOWY**.

## UV MEASUREMENT - OPTIONAL SENSOR

The UVR128 / UVR138 Ultra-Violet Radiation Sensor can be purchased as an optional item. The UV sensor gives you the following information at your fingertips:

- 10-hour Ultra-Violet Index (UVI) record.
- Automatic calculation of acceptable UV exposure times based on pre-set user profiles (4 users maximum).
- UVI Danger Alert when UV Index reaches unsafe levels.

UV data is shown in the same area as the Barometer. Press **SELECT** to navigate to the Barometer Area, then press **MODE** to display the UV icon ☀ and data.



**NOTE** Refer to the UVR128 / UVR138 User Manual for more information and see below to learn about the new additional UV features.

## NEW ADDITIONAL UV FEATURES

### UV EXPOSURE TIME COUNTDOWN

To set the exposure time countdown you need set to the Skin Type and Sun Protection Factor (SPF) as follows:

1. Press **SELECT** to navigate to the Barometer Area, then press **MODE** to select the UV display.

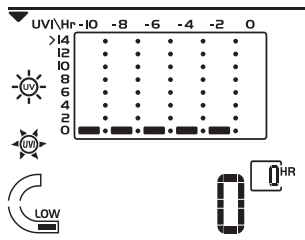

2. Press **CHANNEL** to select user 1-4.
3. Press and hold **MODE** for 2 seconds to enter the Skin Type Setting Mode of the selected user.
4. Press **UP** or **DOWN** to choose 1 of the 4 skin type settings. Then press **MODE** to confirm and enter the SPF Set Up Mode.
5. Press **UP** or **DOWN** to increase or decrease the SPF



value. Then press **MODE** to confirm and enter the UV Exposure Time Countdown Setting Mode.

- Press **UP** or **DOWN** to enable or disable countdown. Press **MODE** to exit the UV Exposure Time Countdown Mode and start the exposure time countdown. The remaining user UV exposure time will display and the **START** will flash.
- When the countdown has reached "0", an alarm will sound for 2 minutes. Press any button to turn the alarm off. The **EXPO TIME** icon will flash for 2 minutes even if you have stopped the alarm sound.

#### MAXIMUM / MINIMUM MEMORY FOR UVI

To view the maximum and minimum memory for UVI:

- Press **SELECT** to navigate to the Barometer Area.
- Press **MODE** to select the UV display.
- Press **MEMORY** to show maximum, minimum and current UVI readings.
- Press and hold **MEMORY** for 2 seconds to clear the UVI memory.

**NOTE** The UV sensor must be activated before you try and set the additional features. Please refer to the UVR128 / UVR138 User Manual for more information.

## TEMPERATURE AND HUMIDITY

The weather station can display the following information from any of the 5 remote sensors:

- Current, minimum, and maximum temperatures and relative humidity percentages.
- Comfort level indicator and trend line (rising, falling, or steady).

Data is collected and displayed approximately every 60 seconds.

#### VIEW TEMPERATURE AND HUMIDITY AREA

Press **SELECT** to navigate to the Temperature and Humidity Areas.

Temperature data is given at the top; Humidity is below.

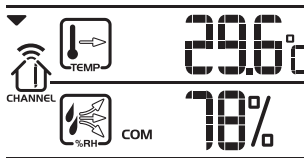

### SELECT MEASUREMENT UNIT

Slide the °C / °F switch (inside the clock battery compartment), to the setting you want.

### SELECT SENSOR CHANNEL

Press **CHANNEL** to switch between sensors 1-5.



The house icon shows the selected remote sensor.

- To auto-scan between sensors, press and hold **CHANNEL** for 2 seconds. Each sensor's data will be displayed for 3 seconds.
- To end auto-scan, press **CHANNEL** or **MEMORY** with the Temperature / Humidity Area selected.

**NOTE** If you select a sensor that collects only temperature data, the humidity will not be shown.

### MINIMUM / MAXIMUM RECORDS

- Press **MEMORY** repeatedly to view current, maximum and minimum records for the selected sensor.
- To clear the records, press and hold **MEMORY** for 2 seconds. A beep will sound to confirm that the memory has been cleared.



### TEMPERATURE AND HUMIDITY TREND

The trend lines are shown next to the temperature and humidity readings.

TREND	RISING	STEADY	FALLING
TEMPERATURE			
HUMIDITY			

### COMFORT ZONE

The Comfort Zone indicates how comfortable the climate is, based on current temperature and humidity measurements.

ZONE	TEMPERATURE	HUMIDITY
WET	Any	>70%
COM	20-25°C (68-77°F)	40-70%
DRY	Any	<40%

**NOTE** This information is shown in the Humidity Area when the current measurement is displayed.





## HEAT INDEX

The Heat Index advises 4 levels of warning if the temperature is high.

DANGER CATEGORY	TEMPERATURE	
	°C	°F
Extreme Danger	>54.5	>130
Danger	40.5-54.4	105-130
Extreme Caution	32.2-40.5	90-105
Caution	26.6-32.2	80-90

To display the Heat Index:

1. Press **SELECT** to navigate to the Temperature Area.  
▼ will show next to the Area.
2. Press **MODE** to reach the Heat Index display.
3. Press **CHANNEL** to select the desired channel.

**NOTE** If the temperature is below 26°C / 80°F, or the desired channel is not working, the Heat Index will display "NA".

## BACKLIGHT

Press **SNOOZE / LIGHT** to illuminate the backlight for 8 seconds.

## RESET SYSTEM

The **RESET** button is located at the bottom of the unit. Press **RESET** when you change the batteries and whenever performance is not behaving as expected (for example, unable to establish radio frequency link with remote unit or clock).

**NOTE** When you press **RESET**, all settings will return to default value, and you will lose all stored information.

## LIGHT BOX

The light box displays different colors to show weather information at a glance:

### Current temperature

COLOR	Pink	Purple	Light Blue	Dark Blue
°C	-10 or below	-10 to 0	0 to 10	10 to 20
°F	14 or below	14 to 32	32 to 50	50 to 68
COLOR	Green	Yellow	Orange	Red
°C	20 to 30	30 to 40	40 to 50	100 or above
°F	68 to 86	86 to 104	104 to 122	212 or above

### Current humidity

COLOR	Orange	Yellow	Green	Light Blue	Dark Blue
%	1-20	20-40	40-60	60-80	80-100

### Weather Forecast

COLOR	Light Blue	Dark Blue	Purple	Pink	Orange
DESCRIPTION	Snowy	Rainy	Cloudy	Partly Cloudy	Sunny

### UV Index (only available if UV sensor is in use)

COLOR	Green	Yellow	Orange	Red	Pink
UV INDEX	0-2	3-5	6-7	8-10	11 or above

To turn the light box ON / OFF, press **LIGHT ON / OFF**.

To select temperature, humidity, weather forecast or UV Index, press **SELECT**.

**NOTE** Weather information is sent from the main unit every 60 seconds. If the connection between the main unit and light box is lost a WHITE color is displayed. To search for the main unit, press and hold **SELECT** for 2 seconds. The red LED will flash to indicate it is in search mode.

### SAFETY AND CARE

Clean the product with a slightly damp cloth and alcohol-free, mild detergent. Avoid dropping the product or placing it in a high-traffic location.

### WARNINGS

This product is designed to give you years of service if handled properly. Oregon Scientific will not be responsible for any deviations in the usage of the device from those specified in the user instructions or any

unapproved alterations or repairs of the product. Observe the following guidelines:

- Placement of this product on wood surfaces with certain types of finishes, such as clear varnish, may result in damage to the finish. Consult the furniture manufacturer's care instructions for direction as to the types of objects that may safely be placed on the wood surface. Oregon Scientific shall not be responsible for any damage to wood surfaces from contact with this product.
- Never immerse the product in water. This can cause electrical shock and damage the product.
- Do not subject the main unit to extreme force, shock, or fluctuations in temperature or humidity.
- Do not tamper with the internal components.
- Do not mix new and old batteries or batteries of different types.
- Do not use rechargeable batteries with this product.
- Remove the batteries if storing this product for a long period of time.
- Do not scratch the LCD display.

**NOTE** The technical specification of this product and contents of this user guide are subject to change without notice. Images not drawn to scale.

**TROUBLESHOOTING**

PROBLEM	SYMPTOM	REMEDY
Barometer	Strange readings	Set altitude / unit
Calendar	Strange date / month	Change language
Clock	Cannot adjust clock	Disable clock radio signal reception
	Cannot auto-synch	<ol style="list-style-type: none"> <li>1. Adjust batteries</li> <li>2. Press <b>RESET</b></li> <li>3. Manually activate clock radio signal reception</li> </ol>
Temp	Shows "LLL" or "HHH"	Temperature is out-of-range
Remote sensor	Cannot locate remote sensor	Check batteries

**SPECIFICATIONS****Main Unit Dimensions**

L x W x H  
120 x 86 x 188 mm  
(4.72 x 3.39 x 7.40 inches)

Weight  
376 grams (0.83 lbs)  
without battery

**Remote Unit Dimensions**

L x W x H  
70 x 24.5 x 116 mm  
(2.76 x 0.96 x 4.57 inches)

Weight  
108 grams (0.24 lbs)  
without battery

**Light Box Dimensions**

L x W x H  
86 x 86 x 25 mm  
(3.9 x 3.9 x 0.9 inches)

Weight  
66 grams (0.14 lbs)

**Temperature**

Unit  
°C or °F  
Indoor Range  
-5 °C to 50 °C  
(23 °F to 122 °F)

Outdoor Range  
-20 °C to 60 °C  
(-4 °F to 140 °F)

Resolution  
0.1 °C (0.2° F)





EN

Comfort 20 °C to 25 °C  
(68 °F to 77 °F)  
Memory Min / Max

**Relative Humidity**

Range 25% to 95%  
Resolution 1%  
Comfort 40% to 70%  
Memory Min / max

**Barometer**

Unit mb / hPa or inHg  
Resolution 1 mb (0.03 inHg)  
Altitude -100 to 2500 metres  
(-328 to 8202 feet)  
Display Sunny (day / night),  
partly cloudy (day / night),  
cloudy, rainy, snowy

**Light Box**

Transmission range 30 metres (98 feet)

**Remote Unit**

RF frequency 433 MHz  
Range Up to 70 metres (230 feet)  
with no obstructions  
Transmission Approx. every 1 minute

Channel No. 1, 2, 3, 4 or 5  
Unit °C or °F

**Clock**

Synchronization Auto or disabled  
Clock display HH:MM:SS  
Hour format 12hr (AM/PM) or 24 hr

Calendar DD / MM or MM / DD;  
Day of the week in 1 of  
5 languages (E, G, F, I, S)

Alarm Daily & Pre-Alarm;  
2-minute crescendo  
Snooze 8-minute snooze

**Power****Main Unit**

Power adapter 6V AC adapter  
Batteries 4 x UM-4 (AAA) 1.5V

**Thermo / Hygro Remote Unit**

Batteries 2 x UM-3 (AA) 1.5V

**NOTE** It is recommended that you use alkaline batteries with this product for longer performance.





Z

## ABOUT OREGON SCIENTIFIC

Visit our website ([www.oregonscientific.com](http://www.oregonscientific.com)) to learn more about Oregon Scientific products such as digital cameras; MP3 players; children's electronic learning products and games; projection clocks; health and fitness gear; weather stations; and digital and conference phones. The website also includes contact information for our Customer Care department in case you need to reach us, as well as frequently asked questions and customer downloads.

We hope you will find all the information you need on our website, however if you're in the US and would like to contact the Oregon Scientific Customer Care department directly, please visit:

[www2.oregonscientific.com/service/support](http://www2.oregonscientific.com/service/support)

OR

Call 1-800-853-8883.

For international inquiries, please visit:

[www2.oregonscientific.com/about/international](http://www2.oregonscientific.com/about/international)

## EC-DECLARATION OF CONFORMITY

Hereby, Oregon Scientific, declares that this Weather Station with Remote Color Changing Light Box model BAR989HG / BAR989HGA is in compliance with the essential requirements and other relevant provisions of Directive 1999/5/EC.

A copy of the signed and dated Declaration of Conformity is available on request via our Oregon Scientific Customer Service.



**COUNTRIES RTTE APPROVAL COMPLIED**

All EC countries, Switzerland (CH)

and Norway (N)

## FCC STATEMENT

This device complies with Part 15 of the FCC Rules. Operation is subject to the following two conditions: (1) This device may not cause harmful interference, and (2) This device must accept any interference received, including interference that may cause undesired operation.

**WARNING** Changes or modifications not expressly approved by the party responsible for compliance could void the user's authority to operate the equipment.

**NOTE** This equipment has been tested and found to comply with the limits for a Class B digital device, pursuant to Part 15 of the FCC Rules. These limits are designed to provide reasonable protection against harmful interference in a residential installation.

This equipment generates, uses and can radiate radio frequency energy and, if not installed and used in accordance with the instructions, may cause harmful interference to radio communications. However, there is no guarantee that interference will not occur in a particular installation. If this equipment does cause harmful interference to radio or television reception, which can be determined by turning the equipment off and on, the user is encouraged to try to correct the interference by one or more of the following measures:

- Reorient or relocate the receiving antenna.
- Increase the separation between the equipment and receiver.
- Connect the equipment into an outlet on a circuit different from that to which the receiver is connected.
- Consult the dealer or an experienced radio / TV technician for help.

## DECLARATION OF CONFORMITY

The following information is not to be used as contact for support or sales. Please call our customer service number (listed on our website at [www.oregonscientific.com](http://www.oregonscientific.com)), or on the warranty card for this product) for all inquiries instead.

### We

Name: Oregon Scientific, Inc.  
Address: 19861 SW 95th Ave., Tualatin,  
Oregon 97062 USA  
Telephone No.: 1-800-853-8883

**declare that the product**

Product No.: BAR989HG / BAR989HGA  
Product Name: Weather Station with Remote  
Color Changing Light Box  
Manufacturer: IDT Technology Limited  
Address: Block C, 9/F, Kaiser Estate,  
Phase 1, 41 Man Yue St.,  
Hung Hom, Kowloon,  
Hong Kong

is in conformity with Part 15 of the FCC Rules. Operation is subject to the following two conditions: 1) This device may not cause harmful interference. 2) This device must