

CABLE FREE WEATHER STATION

MODEL: WMR112 / WMR112U (UK VERSION)

USER'S MANUAL

SECTION 1 INTRODUCTION

Congratulations on your purchasing the WMR112/112U Cable Free Weather Station. An all-purpose easy-to-use system, the WMR112/112U lets you monitor the following weather elements:

- Air temperature
- Relative humidity
- Barometric pressure
- Wind speed and direction
- Rainfall

The WMR112/112U is also equipped with:

- RF calendar clock with daily alarm
- Weather forecast within 32 to 48 km (20- to 30-mile) radius
- Weather alarms
- Memory for maximum and minimum readings
- Touch-screen plus key button operation

STANDARD PACKAGE

The original WMR112/112U comes complete with the following:

- Main unit (WMR112/112U)
- Anemometer (WGR918N)
- Thermo-hygrometer (THGN228NX)
- Rain gauge (PCR918N)
- Baro-thermo-hygrometer (BTHR918N)
- 12V AC adapter

The rain gauge is powered by solar transmitter STR928 while the anemometer is powered by solar transmitter STR938.

The WMR112/112U can support up to seven different remote instruments. You can connect up to three optional thermo or thermo-hygro sensors to the system.

Optional items include:

- Thermo-hygro sensor (THGR228N/THGR238N)
- Thermo sensor (THR228N/THR238N)

Contact an authorized dealer for optional items.

SECTION 2 INSTALLATION

The WMR112/112U operates at 433MHz. No wire installation is required among units.

The WMR112/112U has an effective range of 100 meters in an open area. Position the units within the range and be sure the transmission path is clear of interference and obstacles.

Note: The anemometer, thermo-hygrometer and rain gauge should be installed outdoors and in locations that best measure the weather elements which the instruments are designed for. As for the baro-thermo-hygrometer, it must be installed indoors. If you have any optional thermo or thermo-hygro sensors, they can be installed outdoors or indoors.

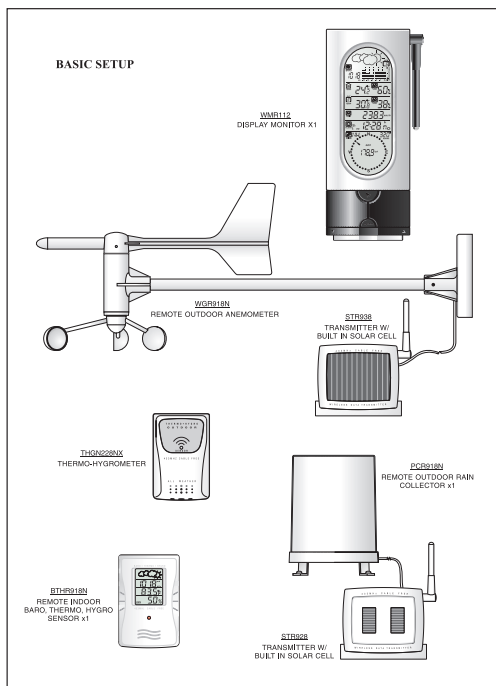

THE ANEMOMETER

The anemometer measures wind speed and direction.

To install it,

1. Unscrew the solar transmitter STR938.
2. Plug in the connector of WGR918N into the solar transmitter as shown.
3. Secure the screws again.

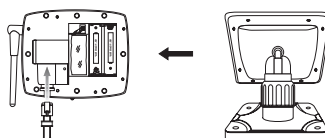

- Place the wind cup over the thinnest shaft on the anemometer's T-bar.

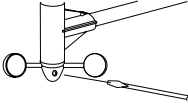

- Tighten the screw on the base of the wind cup.
- Align the red markings on the wind vane's shaft.

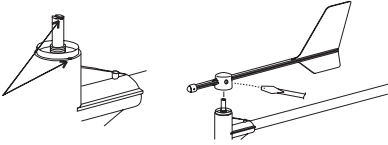

- With the aid of a compass, face the red marking south before mounting the anemometer.

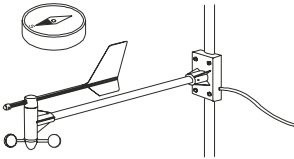

- Mount the anemometer and its solar transmitter safely in place.

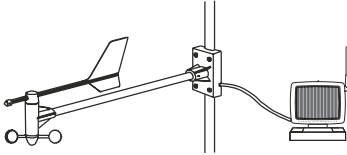

The wind speed and direction window on the main unit should read 180° if the main unit is installed.

- Press [RESET] of STR938 after installation.

THE THERMO-HYGROMETER

The thermo-hygrometer measures outdoor temperature and humidity. It uses two (2) UM-4 or "AAA" size batteries.

Follow these steps to install / replace batteries:

- Remove the screws on the battery compartment.

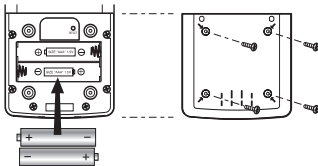

- Insert the batteries strictly according to the polarities shown therein.
- Replace the battery compartment door and secure its screws.
- Press the [RESET] button.

THE RAIN GAUGE

The rain gauge measures the total amount and rate of rainfall.

To install it:

- Unscrew the solar transmitter STR928.
- Plug in the connector of PCR918N into the solar transmitter as shown.
- Secure the screws again.

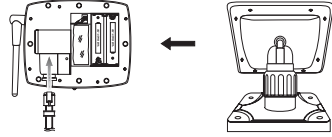

- Open the cover of the rain collector.
- Remove the fiber tape from around the bucket assemblies.



- Mount the rain gauge and its solar transmitter safely in place.
- Put drops of water on the cross at the base on the rain collector to check the leveling.

Water stay at position 1 - 4 means the gauge is not leveled

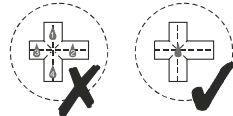

- Use metal ring to adjust the leveling of the rain collector if necessary.

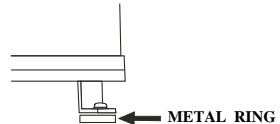

- Close the cover of the rain collector.
- Press [RESET] of STR928 after installation.

THE SOLAR TRANSMITTERS

The solar transmitters make use of solar energy to power the instruments they are connected to. Two pieces of UM3 or "AA" - sized batteries are needed as back-up power.

Note: It is recommended to insert two UM3 or "AA"-sized super lithium batteries for weather condition under 0 °C.

For the solar transmitters to function properly, make sure the solar receptors on the transmitters are exposed to sunlight and the connectors of the connection cable are securely plugged in.

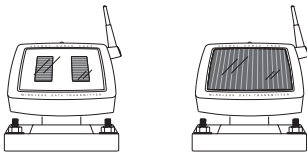

THE BARO-THERMO-HYGROMETER

The baro-thermo-hygrometer measures the atmospheric pressure, temperature and humidity.

The sensor uses four UM4 or “AAA”-sized batteries.

To install it,

1. Insert alkaline batteries accordingly.

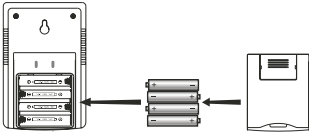

2. Mount the unit where you want to monitor the readings. Or you can make use of its table stand to place it on a flat surface.



THE MAIN UNIT

The main unit gives you all the readings and controls. It should be placed indoors.

The main unit is powered up by the 12V AC adapter.

To install it,

1. Position the main unit and other units within effective range (100 meters).
2. Insert four UM4 or “AAA”-sized alkaline batteries for backup purpose.

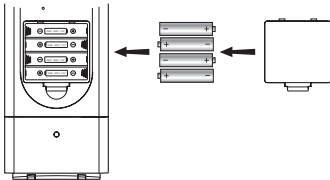

3. Mount the main unit safely in place. Or use its docking bracket to place it on a flat surface.

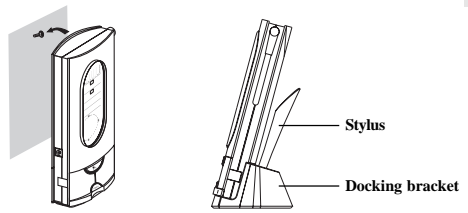

4. Connect the AC power adapter to the main unit and a wall socket.

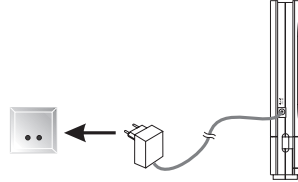

5. Press the [RESET] button on the main unit to initiate operation.

The main unit will start searching for signals for about four minutes. Upon successful reception, the readings will be displayed. The main unit will update the readings at regular intervals.

TABLE-STAND

A docking bracket is provided so that you can rest the unit into it as well as for placement of the Stylus provided. The Stylus is designed to facilitate the touch-screen operation but you can also operate this function simply by touching the screen with your finger.

Caution: Do not press the screen too hard with the Stylus or it would cause damage to the display.

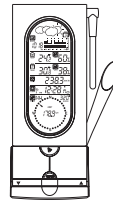

LOW-BATTERY WARNING

There are low-battery indicators [🔋] for the main unit, rain gauge, baro-thermo-hygrometer, thermo-hygrometer and optional remote thermo and thermo-hygro sensors. Replace the batteries when the respective indicators light up.

Note: The readings collected from the thermo-hygrometer and any optional remote thermo and thermo-hygro sensors share the same display window. The “OUT” and remote channel will share the same low-battery indicator. When the battery level of the thermo-hygrometer is low, the low-battery indicator will turn on. If it is one of the optional remote sensors, the low-battery indicator will blink. To locate the channel in question, press the window to scan through all available devices. The low-battery indicator will stop blinking if the battery level is low for that one.

SECTION 3 OPERATION

THE MAIN UNIT

- A WEATHER FORECAST AND BAROMETRIC READING WINDOW
- B INDOOR TEMPERATURE WINDOW
- C INDOOR HUMIDITY WINDOW
- D OUTDOOR/CHANNEL TEMPERATURE WINDOW
- E OUTDOOR/CHANNEL HUMIDITY WINDOW
- F RAINFALL WINDOW
- G RF CALENDAR CLOCK AND DAILY ALARM WINDOW
- H WINDSPEED AND DIRECTION WINDOW
- I CHANNEL BUTTON
- J MEMORY BUTTON
- K ALARM BUTTON
- L SET BUTTON
- M UNIT BUTTON
- N ALARM ON/OFF BUTTON
- O [▼] BUTTON
- P [▲] BUTTON

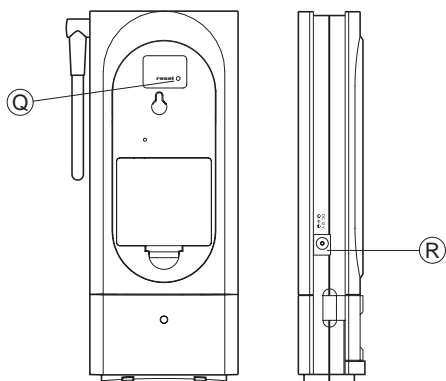
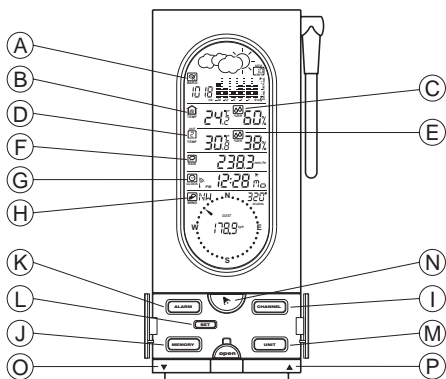

Q [RESET] BUTTON

R DC 12V JACK

THE RF CALENDAR CLOCK

The calendar clock is radio-controlled. It automatically synchronizes its current time and date when it is brought within range of the radio signal generated from Frankfurt, Germany (DCF77). (MSF 60 for UK version)

You can also set the calendar clock manually.

To do so,

1. Press the RF calendar clock and alarm window.
2. Press and hold [▼] to disable the radio reception function.
3. Press and hold [SET] till the digit flash.
4. Use [▲] and [▼] to change to the desired setting.
5. Press [SET] for the next item setting.
6. Repeat from Step 4 to finish all the settings for:
 - Clock display formats (12hr or 24hr)
 - Display language of the day-of-the-week
 - Clock
 - Calendar display formats (Month-Day, Day-Month)
 - Calendar

For the display language, you can choose:

- English (E)
 - German (D)
 - French (F)
 - Italian (I)
 - Spanish (S)
7. Press [SET] to confirm.

The calendar clock and alarm window has three displays: clock with seconds, clock with day-of-the-week and calendar. To change from one display to another, press the window once.

THE DAILY ALARM



To set the daily alarm,

1. Press the RF calendar clock and alarm window.
2. Press [ALARM] and the (•••) indicator will be display to indicate that you are in the alarm mode.
3. Press and hold [SET] till the hour digit flash.
4. Use [▲] and [▼] to change to the desired setting.
5. Press [SET] for minutes setting.
6. Use [▲] and [▼] to change to the desired setting.
7. Press [SET] to confirm.

Note: the window will show “- - - -” if no alarm is armed.

Once set, the alarm clock will be activated automatically and the alarm indicator will light up. When an alarm goes off indicator will flash and a beep sound will be activated for 1 minute. Press any button to stop it. The alarm is still active and will go off again the next day.

To deactivate the function,





1. Press the RF calendar clock and alarm window.
2. Press []. The alarm indicator  will disappear.

ABOUT RADIO CONTROLLED CLOCK RECEPTION

Whenever the WMR112/112U is brought within range of the radio signal with its radio reception function activated, it will search for the clock signal at a predefined time on each day while the manual calendar clock settings will be overridden.

While receiving the signal the radio reception indicator will blink. A complete reception generally takes 2 to 10 minutes, depending on the strength of the radio signal.

The indicator will stop blinking when the reception is complete. The status of reception will be shown:

	- Strong
	- Weak
	- No signal
	- Receiving

To disable the radio reception function:

1. Press the RF calendar clock and alarm window.
2. Press and hold [] to disable the function. The radio reception indicator will disappear.





To enable the function again,

1. Press the RF calendar clock and alarm window.
2. Press and hold [] to enable the function. The radio reception indicator will blink.

WEATHER FORECAST

The weather forecast is displayed in the weather forecast and barometric reading window.

There are four readings for the forecast: sunny, slightly cloudy, cloudy and rainy.

Indicator displays on the unit				
Forecast	Sunny	Slightly Cloudy	Cloudy	Rainy

INDOOR BAROMETRIC READING

The atmospheric pressure reading is displayed in the weather forecast and barometric reading window.



The pressure reading can be displayed in mb (millibars), hPa (Hecto-Pascal), inHg (inch mercury) or mmHg (millimeter mercury).

To select the display unit,





1. Press the weather forecast and barometric reading window.
2. Press [UNIT] repeatedly for the desired setting.

The pressure history for the past 24 hours is displayed in a six-column bar chart.

To display the pressure reading for a particular hour within the past 24 hours,

1. Press the weather forecast and barometric reading window.
2. Press [] and [] for the desired hour.

To set the sea-level pressure,

1. Press the weather forecast and barometric reading window repeatedly till the “sea-level” icon is displayed.
2. Press [] and [] for the current (0 Hr) pressure.
3. Press and hold [SET].
4. Press [] and [] to change to the desired setting.
5. Press [SET] to confirm.

INDOOR AND DEW POINT TEMPERATURES

The current indoor and dew point temperatures, taken by the indoor baro-thermo-hygrometer, are displayed on the indoor temperature window. They can be displayed in degree Centigrade (°C) or Fahrenheit (°F).

To select the display unit,

1. Press the indoor temperature window.
2. Press [UNIT] repeatedly for the desired setting. The selected unit will apply to all temperature displays in this window.

Note: The unit of all temperature related display will be changed simultaneously.

To display the dew point temperature, press the indoor temperature window until the “DEW” indicator is displayed.

To display the maximum and minimum temperatures,

1. Press the indoor temperature window.
2. Press [MEMORY] repeatedly for the desired record. The time and date of the record will also be displayed alternatively with “STAMP” icon in the clock window.

The display will automatically return to the current temperature or dew temperature whatever is displayed before if no key is pressed for about one minute.

To clear the memory,

1. Press the indoor temperature window.
2. Press and hold [MEMORY] till a key tone is heard.
3. Press [MEMORY] to check if the memory is clear.

To display the dew point maximum and minimum temperatures,

1. Press the indoor temperature window or repeatedly until "DEW" icon appear.
2. Press [MEMORY] repeatedly for the desired record. The time and date of the record will also be displayed alternatively with "STAMP" icon in the clock window.

The display will automatically return to the current temperature or dew temperature whatever is displayed before if no key is pressed for about one minute.

To clear the dew point memory,

1. Press the indoor temperature window or repeatedly until "DEW" icon appear.
2. Press and hold [MEMORY] till a key tone is heard.
3. Press [MEMORY] to check if the memory is clear.

INDOOR HUMIDITY

The current indoor relative humidity, taken by the indoor baro-thermo-hygrometer, is displayed on the indoor hygrometer window.

To display the maximum, minimum and current humidity,

1. Press the indoor humidity window.
2. Press [MEMORY] repeatedly for the desired record. The time and date of the record will also be displayed alternatively with "STAMP" icon in the clock window.

To clear the memory,

1. Press the indoor humidity window.
2. Press and hold [MEMORY] till another key tone is heard.
3. Press [MEMORY] to check the memory is clear.

OUTDOOR AND CHANNEL TEMPERATURES

The temperature readings taken by the outdoor thermo-hygrometer and separate thermo or thermo-hygro sensors are displayed on the outdoor and channel temperature window.

As this window can display up to four different sets of data, specify the instrument or channel you want to read.

To do so,

1. Press the outdoor/channel temperature window.
2. Press [CHANNEL] to go from the outdoor reading taken by the outdoor thermo-hygrometer to those taken by individual sensors (Channel 1, 2 or 3).

The outdoor thermo-hygrometer is also capable of detecting the dew point temperature as well as the wind chill reading. To display such information, press the outdoor/channel temperature window repeatedly.

The temperatures can be displayed in degree Centigrade (°C) or Fahrenheit (°F).

To select the display unit,

1. Press the outdoor/channel temperature window.
2. Press [UNIT] repeatedly for the desired setting. The selected unit will apply to all temperature displays in this window.

Note: The unit of all temperature related display will be changed simultaneously.

To display the maximum and minimum temperatures,

1. Press the outdoor/channel temperature window.
2. Press [CHANNEL] for the outdoor thermo-hygrometer or the desired channel.
3. Press [MEMORY] repeatedly for the desired record. The time and date of the record will also be displayed alternatively with "STAMP" icon in the clock window.

To display the dew point temperature for a channel, press the window again when the channel temperature is located.

To clear the memory,

1. Press the outdoor/channel temperature window.
2. Press [CHANNEL] for the outdoor thermo-hygrometer or the desired channel.
3. Press and hold [MEMORY] till a key tone is heard.
4. Press [MEMORY] to check if the memory is clear.

To display the dew point maximum and minimum temperatures,

1. Press the outdoor/channel temperature window or repeatedly until "DEW" icon appear.
2. Press [CHANNEL] for the outdoor thermo-hygrometer or the desired channel.
3. Press [MEMORY] repeatedly for the desired record. The time and date of the record will also be displayed alternatively with "STAMP" icon in the clock window.

To display the dew point temperature for a channel, press the window again when the channel temperature is located.

To clear the dew point memory,

1. Press the outdoor/channel temperature window or repeatedly until "DEW" icon appear.
2. Press [CHANNEL] for the outdoor thermo-hygrometer or the desired channel.
3. Press and hold [MEMORY] till a key tone is heard.
4. Press [MEMORY] to check if the memory is clear.

OUTDOOR AND CHANNEL HUMIDITY

The relative humidity readings taken by the outdoor thermo-hygrometer and separate thermo-hygro sensors are displayed on the outdoor/channel humidity window.

As this window can display up to four different sets of data, specify the instrument or channel you want to read.

To do so,

1. Press the outdoor/channel humidity window.
2. Press [CHANNEL] to go from the outdoor reading taken by the thermo-hygrometer to those taken by individual sensors (Channel 1, 2 or 3).

To display the maximum, minimum and current humidity,

1. Press the outdoor/channel humidity window.
2. Press [CHANNEL] for the outdoor thermo-hygrometer or the desired channel.
3. Press [MEMORY] repeatedly for the desired record. The time and date of the record will also be displayed alternatively with "STAMP" icon in the clock window.

To clear the memory,

1. Press the outdoor/channel humidity window.
2. Press [CHANNEL] for the outdoor thermo-hygrometer or the desired channel.
3. Press and hold [MEMORY] till a key tone is heard.
4. Press [MEMORY] to check if the memory is clear.

AUTO SCANNING FUNCTION

The auto scanning function is available for the outdoor/channel window for both the temperature and humidity.

To use it,

1. Press the outdoor/channel temperature or humidity window.
2. Press and hold [▲] until another key tone is heard. The main unit will start scanning from the active temperature and humidity display. Each channel will be displayed for about 4 seconds.

To exit the auto scanning routine, press any window or control button.

RAINFALL

The rate of rainfall can be displayed in mm/hr or in/hr.

To select the display unit,

1. Press the rainfall window.
2. Press [UNIT] for the desired setting.

To display the yesterday's rainfall and the total rainfall from the last cleared date,

1. Press the rainfall window.
2. Press [MEMORY] for the desired record. Yesterday rainfall will be displayed with "YESTERDAY" shown in the rainfall window. Total rainfall will be displayed with "TOTAL" shown in the rainfall window. The time and date of the record will be displayed alternatively with "SINCE" icon in the clock window for total rainfall.

Note: Yesterday's rainfall record will be updated when the real time clock runs from 11:59:59 pm to 12:00:00 am. And it is counted for 12:00:00 am of one day to 12:00:00 am on the next day.

If the rain sensor detects no rainfall for about two consecutive hours, the current rate of rainfall will be displayed as zero.

To clear the total rainfall,

1. Press the rainfall window.
2. Press and hold [MEMORY] till a key tone is heard.

The yesterday's rainfall record will not be affected when you clear the total rainfall.

WIND SPEED AND DIRECTION

The current wind speed and direction are displayed in the wind speed and direction window.

To display the average wind speed, press the window till the "AVERAGE" icon is displayed.

The wind speed can be displayed in m/s, kph, mph or knots.

To select the display unit,

1. Press the wind speed and direction window.
2. Press [UNIT] for the desired setting.

To display the maximum speed and direction for gust wind in record,

1. Press the wind speed and direction window.
2. Press [MEMORY]. The time and date of the record will also be displayed alternatively with "STAMP" icon in the clock window.

To clear the record,

1. Press the wind speed and direction window.
2. Press and hold [MEMORY] till a key tone is heard.

As for the wind direction, it is displayed in a digital compass with bearing read-outs.

WEATHER ALARMS

Weather alarms are used to alert you to certain weather conditions. Once activated, the alarm will go off when a certain set of criterion is met.

You can set alarms for:

- Indoor, outdoor and channel high temperatures
- Indoor, outdoor and channel low temperatures
- Indoor, outdoor and channel dew point approaching
- Indoor, outdoor and channel high humidity
- Indoor, outdoor and channel low humidity
- High rainfall rate
- Pressure drop
- High gust wind
- Low wind chill

To set a weather alarm,

1. Press the window containing the weather element you want to set.
2. Press [ALARM]. The current alarm setting will be displayed.
3. Press and hold [SET].
4. Press [▲] and [▼] for the desired setting.
5. Press [SET].

For temperatures and humidity, the high and low alarms can be set in sequence. After entering the value for one alarm, you will be prompted to enter the value for the other.

A weather alarm is activated once set. When the set criteria are met, an alarm will go off and the current reading will flash together with the corresponding indicator.

If that happens in the outdoor/channel temperature or humidity window, the "OUT" indicator will flash to show that the criteria set for the outdoor thermo-hygrometer have been met. If it is one of the separate sensors, the [CHANNEL] indicator will flash. Press the window repeatedly to locate the channel in question.

When a weather alarm goes off, press any button to stop the alarm. The alarm is still active until you deactivate the function or the criteria are no longer met.

To do so,

1. Press the window containing the weather element you want to set.
2. Press [ALARM].
3. Press [] to deactivate the function.

To turn on the function again, simply follow the same procedure and press [].

DISCONNECTED SIGNALS

If without obvious reason the display for the main unit goes blank or “- - -” are displayed, press and hold [CHANNEL] to enforce an immediate search.

If that fails, check:

- All weather instruments are still in place.
- The batteries of the main unit and individual weather instruments are still good. Replace them if necessary. Press and hold [CHANNEL] to enforce an immediate search afterwards.
- The transmission is within range and path is cleared of obstacles and interference. Shorten the distance if necessary.

Then press and hold [CHANNEL] again. The main unit will start searching for all previously locked weather instruments.

If you want to add an new sensor, press the reset button on the new sensor and then press [CHANNEL] to enforce the main unit to search.

- Note:**
1. Do not reset the sensors after the main unit has locked those sensors, otherwise the main unit will no longer receive the signal from those sensors.
 2. If you have disconnected signals, you cannot clear the memory.

THE RESET BUTTON

This button is only used when the system is operating in an unfavorable way or malfunctioning. Use a blunt stylus to hold down the button. The main unit will return to all default settings and start searching for signals again.

Before resetting the main unit, you should do the same for all weather instruments to ensure correct transmission and reception of signals. Then press [RESET] on the main unit.

MAINTENANCE

When handled properly, this unit is engineered to give you years of satisfactory service. Here are a few product care instructions:

1. Do not immerse the unit in water. If the unit comes in contact with water, dry it immediately with a soft lint-free cloth.
2. Do not clean the unit with abrasive or corrosive materials. Abrasive cleaning agents may scratch the plastic parts and corrode the electronic circuit.
3. Do not subject the unit to excessive: force, shock, dust, temperature, or humidity. Such treatment may result in malfunction, a shorter electronic life span, damaged batteries, or distorted parts.
4. Do not tamper with the unit's internal components. Doing so will terminate the unit's warranty and may cause damage. The unit contains no user-serviceable parts.

5. Only use new batteries as specified in this instruction manual. Do not mix new and old batteries as the old batteries may leak.
6. Read this instruction manual thoroughly before operating the unit.

SPECIFICATIONS

Temperature

Proposed Operating Range : Indoor -5°C to 50°C
(23°F to 122°F)
: Outdoor -20°C to 60°C
(-4°F to 140°F)

Resolution : 0.1°C (0.2°F)
(indoor and outdoor)

Relative Humidity

Measuring Range : 25 to 90% RH
(indoor and outdoor)

Resolution : 1% RH
(indoor and outdoor)

Dew Point Temperature

Measuring Range : Indoor -5°C to 50°C
(23°F to 122°F)

: Outdoor -10°C to 60°C
(14°F to 140°F)

Resolution : 1°C (2°F)
(indoor and outdoor)

Barometric Pressure /Trend

Measuring Range : 600 to 1050 mb
(17.72 to 31.01 inHg)

Resolution : 1 mb (0.03 inHg)

Wind Speed

Measuring Range : 0 to 56 m/s (0 to 125.3 mph)

Resolution : 0.2 m/s (0.4 mph) (typical)

Wind Direction

Measuring Range : 0° to 359° (Degrees)

Digital Resolution : 1° (typical)

Graphical Resolution : 10°

Wind Chill Temperature

Measuring Range : -52°C to 60°C (-61.6°F to 140°F)

Resolution : 1°C (2°F)

Rainfall

Daily and Cumulative : 0 to 9999 mm (0 to 393.7 in)

Measuring Range

Rainfall Rate : 0 to 999 mm/hr (0 to 39.37 in/hr)

Measuring Range

Daily and Cumulative : 1 mm (0.04 inch)

Resolution

Rainfall Rate Resolution : 1mm/hr (0.04 m/h) typical

WMR112/112U :

Weight : 505 g
 Dimension : 36 (L) x 90 (W) x 196 (H)
 Power : 12V AC / DV adapter
 Power backup : 4 x UM4 - "AAA" size alkaline battery

WGR918N :

Weight : 430 g
 Dimension : 295 (L) x 116.5 (W) x 550 (H)
 Power : solar cell (STR938)

THGN228NX :

Weight : 100 g
 Dimension : 92 (L) x 60 (W) x 21 (H)
 Power : Main : 2 x UM4 - "AAA" size alkaline battery

PCR918N :

Weight : 276 g
 Dimension : Ø 113.5 x 145 (H)
 Power : Main : solar cell (STR928)

BTHR918N :

Weight : 78.4 g
 Dimension : 180 (L) x 70 (W) x 19 (H)
 Power : 4 x UM4 - "AAA" size alkaline battery

STR928 :

Weight : 266 g
 Dimension : 115 (L) x 81 (W) x 138 (H)
 Power back up : 2 x UM3- "AA" size alkaline battery
 (recommend super lithium battery for weather condition under 0°C)

STR938 :

Weight : 290 g
 Dimension : 115 (L) x 81 (W) x 138 (H)
 Power back up : 2 x UM3- "AA" size alkaline battery
 (recommend super lithium battery for weather condition under 0°C)

CAUTION

- The content of this manual is subject to change without further notice.
- Due to printing limitation, the displays shown in this manual may differ from the actual display.
- The contents of this manual may not be reproduced without the permission of the manufacturer.

NOTE ON COMPLIANCE

Warning: Changes or modifications to this unit not expressly approved by the party responsible for compliance could void the user's authority to operate the equipment.

R&TTE Compliance Note

This device complies with the essential requirements of Article 3 of the R&TTE 1999/5/EC Directive, if used for its intended use and that the following standard(s) has been applied:

Electromagnetic compatibility (Article 3.1.b of the R&TTE Directive)

Applied standards ETS 300 683 : 1997

Efficient use of the radio frequency spectrum (Article 3.2 of the R&TTE Directive)

Applied standards EN300 220 -1 : 1997

INTENDED USE OF THE DEVICE