



**USB Weather Station Kit
Model: WMRS200**

USER MANUAL

USB Weather Station Kit

Model: WMRS200

USER MANUAL

INTRODUCTION

Thank you for selecting the Oregon Scientific™ USB Weather Station Kit (WMRS200).

With easy PC uploading capability via USB, the USB Weather Station Kit (WMRS200) displays the collected weather data on your PC in a convenient and intuitive way.

The weather station is capable of connecting to a PC computer using the USB connection. The software can read the latest weather data collected from the base station. Please download the software from the following website:

<http://10.1.6.110/wmrs200.exe>

For full details see the software instructions.

PC System requirements

The minimum system requirements for use of the software is:

- Operating system: Microsoft Windows 98 or above
- Processor: 300 MHz or above CPU speed
- RAM: Min. 128Mb
- Hard disk free space: Min. 50Mb
- CD-ROM or DVD drive

The USB communications hub is compatible with other sensors. To purchase additional sensors, please contact your local retailer.

Sensors with this logo  are compatible with this unit.

NOTE Please keep this manual handy as you use your new product. It contains practical step-by-step instructions, as well as technical specifications and warnings you should know about.

PACKAGING CONTENTS

USB COMMUNICATIONS HUB



1 x USB Communications Hub







1 x USB cable

CONTENTS

INTRODUCTION	1
PACKAGING CONTENTS	1
USB Communications Hub	1
Wind Sensor / Temperature & Humidity Sensor	2
Rain Gauge	2
Assembly Parts	2
ACCESSORIES - SENSORS	2
OVERVIEW	2
Front View	2
Back View	2
Wind Sensor	3
Rain Gauge	3
Outdoor Temperature / Humidity Sensor	3
GETTING STARTED	3
Set Up Remote Wind Sensor	3
Set Up Remote Temperature / Humidity Sensor	4
REMOTE UNIT ASSEMBLY	4
Remote Wind Sensor on Existing Pole	4
Temperature/Humidity Sensor Mounted Separately ...	4
Set Up Rain Gauge	4
GETTING STARTED	5
Set Up USB Communications Hub	5
Sensor Data Transmission	5
VIEW READINGS ON PC	5
To disable sleep mode on PC	5
RESET	6
TROUBLE SHOOTING	6
SPECIFICATIONS	6
PRECAUTIONS	7
ABOUT OREGON SCIENTIFIC	7
EU-DECLARATION OF CONFORMITY	7
FCC STATEMENT	7

WIND SENSOR / TEMPERATURE & HUMIDITY SENSOR

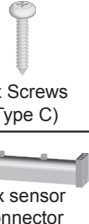
 <p>1 x Wind Sensor (1 x Wind Vane Above and 1 x Anemometer Below)</p>	 <p>1 x Aluminium pole</p>	 <p>2 x AA UM-3 1.5V batteries</p>
 <p>1 x Temperature / Humidity Sensor casing</p>	 <p>1 x Temperature / Humidity Sensor</p>	 <p>4 x Screws (Type C) 1 x sensor connector</p>

- Thermo-hygro THGR810 (10-Ch)
- UV UVN800

* Features and accessories will not be available in all countries.



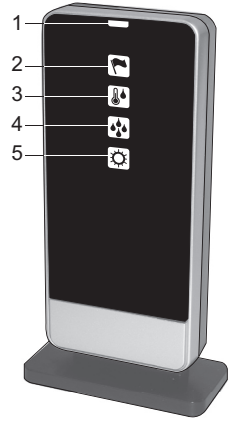

OVERVIEW

FRONT VIEW



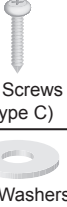

1. Indicates a successful USB connection / Unit is ON
2. Indicates Wind Sensor reception status
3. Indicates Outdoor Thermo-Hygro Sensor reception status
4. Indicates Rain Gauge reception status
5. Indicates UV Sensor reception status

RAIN GAUGE

 <p>1 x Rain Collector</p>	 <p>1 x Filter</p>	 <p>4 x Screws (Type C) 6 X Washers</p>
 <p>2 x AA UM-3 1.5V batteries</p>		

ASSEMBLY PARTS

 <p>1 x Horizontal Attachment Bracket</p>	 <p>1 x Versatile Base (Wall or Ground Fixable)</p>	 <p>2 x Round U- bolts</p>
---	--	---

ACCESSORIES - SENSORS

This product can work with up to 10 sensors at any one time to capture outdoor temperature, relative humidity or UV readings in various locations.

Optional wireless remote sensors such as those listed below can be purchased separately. For more information, please contact your local retailer.*

- Solar Panel STC800 connectable to Wind Sensor and Temperature / humidity sensor
- Thermo-hygro THGR800 (3-Ch)

BACK VIEW

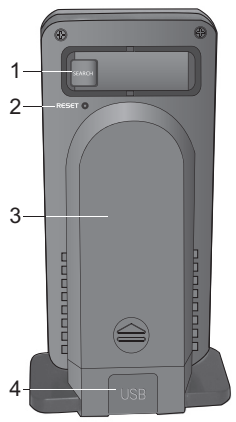

1. **SEARCH:** Initiate search for remote sensors
2. **RESET:** Reset unit to default settings
3. Battery compartment
4. USB socket: Upload records to PC / charge rechargeable battery

WIND SENSOR

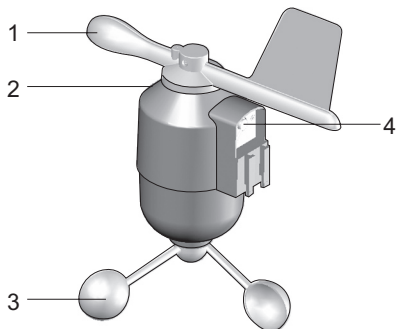

1. Wind direction
2. Wind vane casing
3. Anemometer
4. Solar power socket

RAIN GAUGE

Base and funnel:

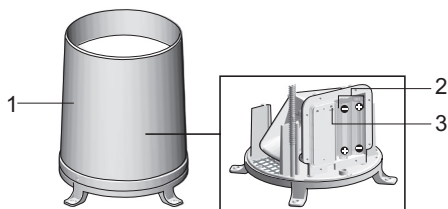

1. Rain Gauge
2. Battery compartment
3. **RESET** button

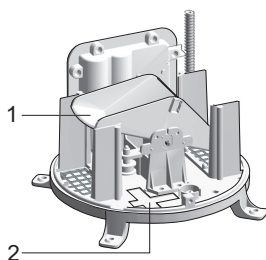

1. Funnel
2. Indicator

OUTDOOR TEMPERATURE / HUMIDITY SENSOR

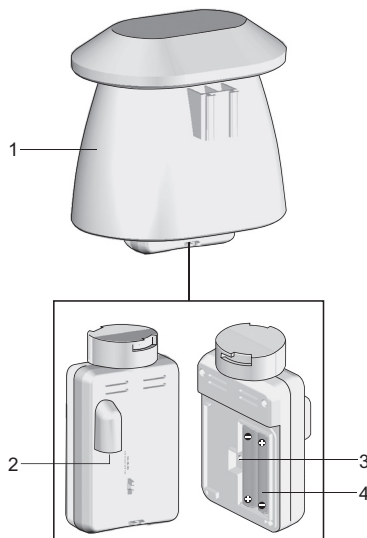

1. Temperature / humidity sensor casing
2. Solar power socket
3. **RESET** button
4. Battery compartment

GETTING STARTED

SET UP REMOTE WIND SENSOR

The wind sensor takes wind speed and direction readings.

The sensor is battery operated. It is capable of transmitting data to the USB communications hub wirelessly within an approximate operating range of 100 meters (328 feet).

IMPORTANT Ensure that the wind sensor is pointing North to enable it to record accurate readings.

NOTE The sensor should be positioned in an open area away from trees or other obstructions.

To insert batteries:

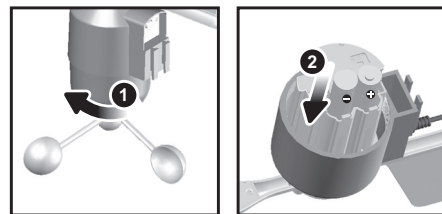

1. Unscrew the anemometer from the wind sensor carefully.
2. Insert batteries matching the polarities (+ / -) and replace the anemometer. Press **RESET** after each battery change.

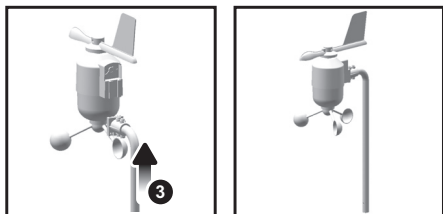

- Slide wind vane onto the end of the plastic attachment located on the aluminium pole.

NOTE Use alkaline batteries for longer usage and consumer grade lithium batteries in temperatures below freezing.

SET UP REMOTE TEMPERATURE / HUMIDITY SENSOR

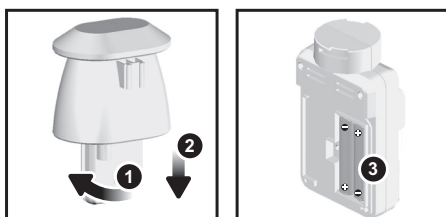

- Holding sensor, twist and click to the left.
- Pull sensor away from casing.
- Insert batteries matching the polarities (+ / -). Press **RESET** after each battery change.

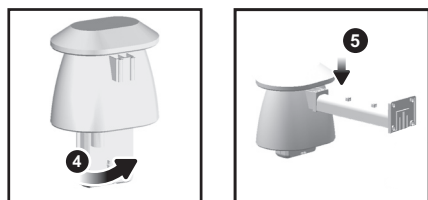

- Insert sensor into the casing, twist and click to the right to secure.
- Slide temperature and humidity sensor onto the smaller end of the sensor connector.

REMOTE UNIT ASSEMBLY

REMOTE WIND SENSOR ON EXISTING POLE

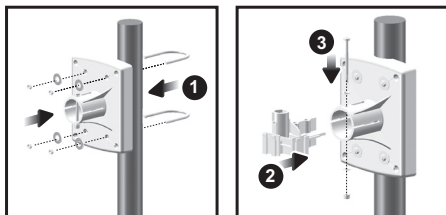

- Secure the plastic base onto existing pole with U-bolts, washers and bolts.

- Insert the horizontal attachment bracket into the base.
- Using a screw, fix firmly into place.



- Insert wind sensor into the top of the bracket.
- Using screws, fix aluminium pole firmly into place.
- Slide outdoor sensor onto bracket.

IMPORTANT For best results, point the wind vane North.



TEMPERATURE / HUMIDITY SENSOR MOUNTED SEPARATELY

- Insert 4 type A screws into the holes of the sensor connector. Screw firmly into place, i.e., fence.

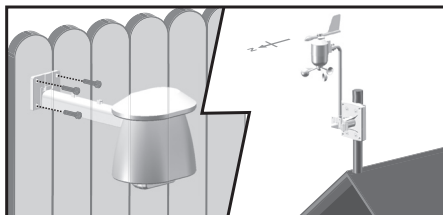

SET UP RAIN GAUGE

The rain gauge collects rain and takes readings of rainfall rate and the total rainfall over a period of time. The sensor can remotely transmit data to the USB communications hub.

The USB communications hub and rain gauge should be positioned within an effective range: about 100 meters (328 feet) in an open area.

The rain gauge should be mounted horizontally about 1 meter (3 feet) from the ground in an open area away from trees or other obstructions to allow rain to fall naturally for an accurate reading.

To set up the Rain Gauge:

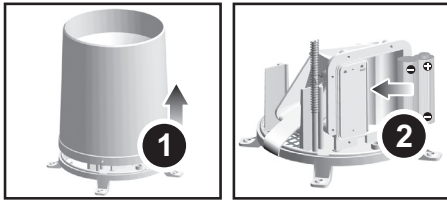

1. Remove screws and slide the cover off in an upwards motion.
2. Insert the batteries (2 x UM-3 / AA), matching the polarities (+ / -). Press **RESET** after each battery change.

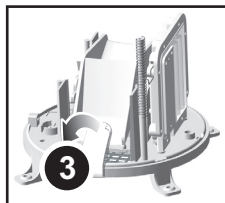

3. Remove the fibre tape.

To ensure a level plane:

Put a few drops of water on the cross at the base of the funnel to check the horizontal level.

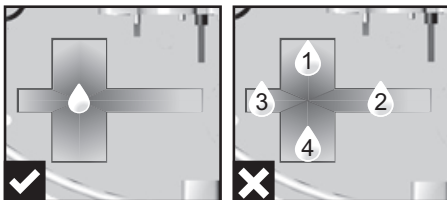

Water will pool to the center of the cross when the rain gauge is level.

If water remains on 1-4, the gauge is not horizontal.

If necessary, adjust the level using the screw.

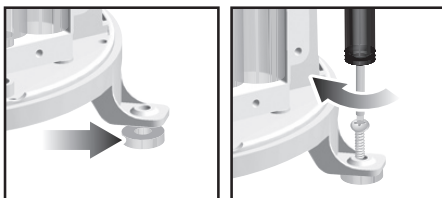

NOTE For best results, ensure the base is horizontal to allow maximum drainage of any collected rain.

GETTING STARTED

SET UP USB COMMUNICATIONS HUB

NOTE Install batteries matching the polarities (+ / -) in the remote sensors before installing the USB communications hub.

For continuous use, connect the USB communications hub to computer using USB cable provided. A rechargeable battery is included for back-up use only.

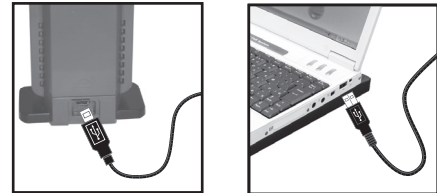

NOTE Batteries should not be exposed to excessive heat such as sunshine or fire.

SENSOR DATA TRANSMISSION

To search for a sensor:

Press and hold **SEARCH** located at the back of USB communications hub.



Icons will flash during search mode.

Continuous display of icons indicate that the respective remote sensor has been successfully logged.

NOTE Unit will search only for already registered sensor or new sensor reset within last 30 minutes. To register a new sensor, reset sensor prior to search.

TIP The transmission range may vary depending on many factors. You may need to experiment with various locations to get the best results.

VIEW READINGS ON PC

To upload records to PC:

Plug USB and upload onto computer. For your convenience, rechargeable battery will automatically be charged.

NOTE PC program must be installed before uploading of records from USB communications hub.

IMPORTANT Ensure sleep mode on computer is disabled as this will adversely affect the operation of this unit.

TO DISABLE SLEEP MODE ON PC

1. Right Click on Desktop.
2. Choose Properties.
3. Click on "Screen Saver" Tab in the "Display Properties" window.
4. Click on "Power" located on bottom half of window.
5. A new window "Power Options Properties" will open.

6. Under "System standby" option, choose "Never" in drop down menu.
7. Click "Apply" and then click "OK".
8. Previous window will return. Click "OK" to confirm and exit.

RESET

Press **RESET** to return to the default settings.

TROUBLE SHOOTING

PROBLEM	SYMPTOM	REMEDY
Sensor	 <p>Icons are not displayed.</p>	<ol style="list-style-type: none"> 1. Check sensor batteries 2. Check if sensors are within range 3. Check USB communications hub is connected to USB
PC	Cannot upload	<ol style="list-style-type: none"> 1. Check the PC software is setup and running 2. Check PC is connected with the USB communications hub via USB

SPECIFICATIONS

USB COMMUNICATIONS HUB

Dimensions (L x W x H)	68 x 46 x 136 mm (2.7 x 1.8 x 5.4 inches)
Weight	92 g (0.2 lbs) without battery

INDOOR BAROMETER

Barometer unit	mb/hPa, inHg and mmHg
Measuring range	700 – 1050mb/hPa
Accuracy	+/- 10 mb/hPa
Resolution	1mb (0.0 inHg)
Altitude setting	Sea level User setting for compensation
Weather display	Sunny, Clear night, Partly Cloudy, Cloudy, Cloudy at night, Rainy and Snowy
Memory	Historical data and bar chart for last 24hrs

INDOOR TEMPERATURE

Temp. unit	°C / °F
Displayed range	0°C to 50°C (32°F to 122°F)
Operating range	-30°C to 60°C (-4°F to 140°F)
Accuracy	0°C - 40°C: +/- 1°C (+/- 2.0°F) 40°C - 50°C: +/- 2°C (+/- 4.0°F)
Comfort	20°C to 25°C (68°F to 77°F)
Memory	Current, Min and Max temp. Dew Point w/ Min and Max
Alarm	Hi / Lo

INDOOR RELATIVE HUMIDITY

Displayed range	2% to 98%
Operating range	25% to 90%
Resolution	1%
Accuracy	25% - 40%: +/- 7% 40% - 80%: +/- 5% 80% - 90%: +/- 7%
Comfort	40% to 70%
Memory	Current, Min and Max
Alarm	Hi / Lo

REMOTE WIND SENSOR UNIT

Dimensions (L x W x H)	178 x 76 x 214 mm (7 x 3 x 8.4 inches)
Weight	100 g (0.22 lbs) without battery
Wind speed unit	m/s, kph, mph, knots
Speed accuracy	2 m/s ~ 10 m/s (+/- 3 m/s) 10 m/s ~ 56 m/s (+/- 10%)
Direction accuracy	16 positions
Transmission of wind speed signal	Approx. every 14 seconds
Memory	Max speed gust
Battery	2 x UM-3 (AA) 1.5V batteries

OUTDOOR TEMPERATURE / HUMIDITY UNIT RELATIVE TEMPERATURE

Dimensions (L x W x H)	115 x 87 x 118 mm (4.5 x 3.4 x 4.6 inches)
Weight	130 g (0.286 lbs) without battery
Temp. unit	°C / °F
Displayed range	-50°C to 70°C (-58°F to 158°F)
Operating range	-30°C to 60°C (-4°F to 140°F)
Accuracy	-20°C - 0°C: +/- 2°C (+/- 4.0°F) 0°C - 40°C: +/- 1°C (+/- 2.0°F) 40°C - 50°C: +/- 2°C (+/- 4.0°F) 50°C - 60°C: +/- 3°C (+/- 6.0°F)
Comfort	20°C to 25°C (68°F to 77°F)
Memory	Current, Min and Max temp. Dew Point w/ Max and Min Wind chill temp. and min

RELATIVE HUMIDITY

Displayed range	2% to 98%
Operating range	25% to 90%
Resolution	1%
Accuracy	25% - 40%: +/- 7% 40% - 80%: +/- 5% 80% - 90%: +/- 7%
Comfort	40% to 70%
Memory	Current, Min and Max
Battery	2 x UM-4 (AAA) 1.5V batteries

RF TRANSMISSION

RF frequency	433MHz
Range	Up to 100 meters (328 feet) with no obstructions
Transmission	Approx. every 60 seconds
No. of Channel	1 for Wind/ Rain/ UV and 10 for Temp. / Humidity

REMOTE RAIN GAUGE

Dimensions	107 x 87 x 56 mm (L x W x H) (4.2 x 3.4 x 2.2 inches)
Weight	134 g (0.3 lbs) without battery
Rainfall unit	Mm/hr and in/hr
Range	0 mm/hr – 999 mm/hr
Resolution	1 mm/hr
Accuracy	< 15 mm/hr: +/- 1 mm 15 mm to 9999 mm: +/- 7%
Memory	Past 24hrs, hourly and accumulated from last memory reset
Battery	2 x UM-3 (AA) 1.5V

PRECAUTIONS

- Do not subject the unit to excessive force, shock, dust, temperature or humidity.
- Do not cover the ventilation holes with any items such as newspapers, curtains etc.
- Do not immerse the unit in water. If you spill liquid over it, dry it immediately with a soft, lint-free cloth.
- Do not clean the unit with abrasive or corrosive materials.
- Do not tamper with the unit's internal components. This invalidates the warranty.
- Only use fresh batteries. Do not mix new and old batteries.
- Images shown in this manual may differ from the actual display.
- When disposing of this product, ensure it is collected separately for special treatment.
- Placement of this product on certain types of wood may result in damage to its finish for which Oregon Scientific will not be responsible. Consult the furniture manufacturer's care instructions for information.
- The contents of this manual may not be reproduced without the permission of the manufacturer.
- Do not dispose old batteries as unsorted municipal waste. Collection of such waste separately for special treatment is necessary.
- Please note that some units are equipped with a battery safety strip. Remove the strip from the battery compartment before first use.

NOTE The technical specifications for this product and the contents of the user manual are subject to change without notice.

ABOUT OREGON SCIENTIFIC

Visit our website (www.oregonscientific.com) to learn more about Oregon Scientific products. If you're in the US and would like to contact our Customer Care department directly, please visit:

www2.oregonscientific.com/service/support

OR

Call 1-800-853-8883.

For international inquiries, please visit:

www2.oregonscientific.com/about/international

EU-DECLARATION OF CONFORMITY

Hereby, Oregon Scientific, declares that this USB Weather Station Kit (models: WMRS200) is in compliance with the essential requirements and other relevant provisions of Directive 1999/5/EC. A copy of the signed and dated Declaration of Conformity is available on request via our Oregon Scientific Customer Service.



COUNTRIES RTTE APPROVAL COMPLIED
All EU countries, Switzerland 
and Norway 

FCC STATEMENT

This device complies with Part 15 of the FCC Rules. Operation is subject to the following two conditions: (1) This device may not cause harmful interference, and (2) This device must accept any interference received, including interference that may cause undesired operation.

WARNING Changes or modifications not expressly approved by the party responsible for compliance could void the user's authority to operate the equipment.

NOTE This equipment has been tested and found to comply with the limits for a Class B digital device, pursuant to Part 15 of the FCC Rules. These limits are designed to provide reasonable protection against harmful interference in a residential installation.

This equipment generates, uses and can radiate radio frequency energy and, if not installed and used in accordance with the instructions, may cause harmful interference to radio communications. However, there is no guarantee that interference will not occur in a particular installation. If this equipment does cause harmful interference to radio or television reception, which can be determined by turning the equipment off and on, the user is encouraged to try to correct the interference by one or more of the following measures:

- Reorient or relocate the receiving antenna.
- Increase the separation between the equipment and receiver.
- Connect the equipment into an outlet on a circuit different from that to which the receiver is connected.
- Consult the dealer or an experienced radio / TV technician for help.

DECLARATION OF CONFORMITY

The following information is not to be used as contact for support or sales. Please call our customer service number (listed on our website at www.oregonscientific.com), or on the warranty card for this product) for all inquiries instead.

We

Name: Oregon Scientific, Inc.
Address: 19861 SW 95th Ave., Tualatin,
Oregon 97062 USA
Telephone No.: 1-800-853-8883

declare that the product

Product No.: WMRS200
Product Name: USB Weather Station Kit
Manufacturer: IDT Technology Limited
Address: Block C, 9/F, Kaiser Estate,
Phase 1, 41 Man Yue St.,
Hung Hom, Kowloon,
Hong Kong

is in conformity with Part 15 of the FCC Rules.
Operation is subject to the following two conditions:

- 1) This device may not cause harmful interference.
- 2) This device must accept any interference received, including interference that may cause undesired operation.

